

T-Max Applicator

Model: 256383

US Patent No. D588,230 S
 Indian Patent No. 218331
 Chinese Patent No. ZL200830142725.X
 European Registered Design No. 000996236-0001
 Japanese Patent No. 1380673
 Korean Patent No. 30-556464



IMPORTANT SAFETY INSTRUCTIONS. Refer to your sprayer instruction manual for Pressure Relief, priming and spray instructions. Keep these instructions.

Maximum Fluid Working Pressure: 1,000 psi (6.9 MPa, 69 bar)

Maximum Air Working Pressure: 250 psi (1.7 MPa, 17 bar)



312879D
ENG

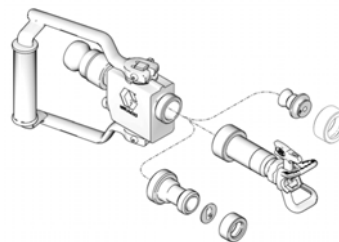

ti11784a

- For Water-Based Materials Only -

The following Warnings are for the setup, use, grounding, maintenance and repair of this equipment. The exclamation point symbol alerts you to a general warning and hazard symbols refer to procedure-specific risks. Refer back to these Warnings. Additional, product-specific warnings may be found throughout the body of this manual where applicable.



WARNINGS



PRESSURIZED EQUIPMENT HAZARD

Fluid from the applicator/dispense valve, leaks, or ruptured components can splash in the eyes or on skin and cause serious injury.

- Follow **Pressure Relief Procedure** in this manual, when you stop spraying and before cleaning, checking, or servicing equipment.
- Tighten all fluid connections before operating the equipment.
- Check hoses, tubes, and couplings daily. Replace worn or damaged parts immediately.



FIRE AND EXPLOSION HAZARD

Flammable fumes, such as solvent and paint fumes, in **work area** can ignite or explode. To help prevent fire and explosion:

- Keep work area free of debris, including solvent, rags and gasoline.
- Ground all equipment in the work area. See **Grounding** instructions.
- If there is static sparking or you feel a shock, **stop operation immediately**. Do not use equipment until you identify and correct the problem.



EQUIPMENT MISUSE HAZARD

Misuse can cause death or serious injury.

- Do not operate the unit when fatigued or under the influence of drugs or alcohol.
- Do not exceed the maximum working pressure or temperature rating of the lowest rated system component. See **Technical Data** in all equipment manuals.
- Use fluids and solvents that are compatible with equipment wetted parts. See **Technical Data** in all equipment manuals. Read fluid and solvent manufacturer's warnings. For complete information about your material, request MSDS forms from distributor or retailer.

- Check equipment daily. Repair or replace worn or damaged parts immediately with genuine manufacturer's replacement parts only.
- Do not alter or modify equipment.
- Use equipment only for its intended purpose. Call your distributor for information.
- Route hoses and cables away from traffic areas, sharp edges, moving parts, and hot surfaces.
- Do not kink or over bend hoses or use hoses to pull equipment.
- Keep children and animals away from work area.
- Comply with all applicable safety regulations.



PERSONAL PROTECTIVE EQUIPMENT

You must wear appropriate protective equipment when operating, servicing, or in the operating area of the equipment to help protect you from serious injury. This equipment includes but is not limited to:

- Protective eyewear and hearing protection
- Clothing and respirator as recommended by the fluid and solvent manufacturer
- Gloves

Pressure Relief Procedure



WARNING



Follow this **Pressure Relief Procedure** whenever instructed to relieve pressure, stop spraying, check or service equipment, or install or clean spray tip.

1. Turn OFF power and turn sprayer pressure control to lowest pressure setting.
2. Hold applicator against side of hopper. Open applicator into hopper to relieve pressure.

If you suspect spray tip or hose is clogged or that pressure has not been fully relieved after following the steps above, slowly loosen retaining nut at base of pump to relieve pressure gradually. Clear hose or tip obstruction.

Airless Spray Setup



WARNING



To prevent injury when the applicator is not in use, always relieve pressure if sprayer is being shut down or left unattended.

Make sure sprayer is turned off and unplugged from power source. Refer to your sprayer instruction manual for priming and spray instructions.

Connect Applicator to Sprayer

1. Attach supply hose to sprayer fluid outlet.
2. Attach other end of supply hose to applicator swivel (17).
3. Refer to sprayer instruction manual for priming instructions.

Install Applicator Tip and Guard



WARNING



1. If equipment has recently been operated, **relieve pressure.**

2. Using a pencil or similar object, insert seal (20) into back of guard (18).
3. Install guard (18) onto end of applicator (9).
4. Insert tip (19) in guard (18). Tighten retaining nut.

Operation

Spraying

1. Be sure the arrow shaped tip (19) faces forward (spray).
2. Hold applicator perpendicular and approximately 40 in. (1 m) from surface. Move applicator first, then open applicator to spray a test pattern.
3. Slowly increase pump pressure until coverage is uniform and even (see sprayer instruction manual for additional information).

Aligning Spray



WARNING



1. **Relieve pressure.**

2. Loosen guard retaining nut.
3. Align guard (18) horizontally to spray a horizontal pattern.
4. Align guard (18) vertically to spray a vertical pattern.

(3) Horizontal

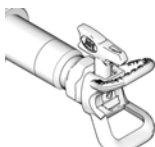

ti11908a

(4) Vertical

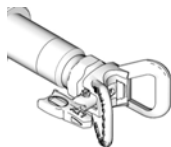

ti11909a

Clearing Clogs



WARNING

1. Close applicator.
2. Rotate tip (19) 180°. Open applicator into hopper or onto ground to remove clog.
3. Rotate tip (19) 180° back to spray position.

Cleanup

Flush applicator after each work shift and store in a dry location. Do not leave the applicator or any parts in water or cleaning solvents.

Air Spray Setup



WARNING



To prevent injury when the applicator is not in use, always relieve pressure if sprayer is being shut down or left unattended.

Connect Applicator to Sprayer

1. Attach supply hose to sprayer fluid outlet.
2. Attach other end of supply hose to applicator swivel (17).
3. Install air hose to applicator check valve (8).
4. Refer to sprayer instruction manual for priming instructions.

Install Applicator Air Nozzle



WARNING



1. If equipment has recently been operated, **relieve pressure.**
2. Install air nozzle (27) and retainer (10).
3. Replace retainer with Fine Finish Kit (40) for finer finishes.

Operation

Spraying

1. Set material flow (see sprayer instruction manual for additional information).
2. Spray test pattern
3. Turn air knob on and adjust, and/or select another air nozzle, for desired pattern.

Note: Air continues to flow when handle is in off position to keep material out of air passages.

Cleanup

Flush applicator after each work shift and store in a dry location. Do not leave the applicator or any parts in water or cleaning solvents.

Parts

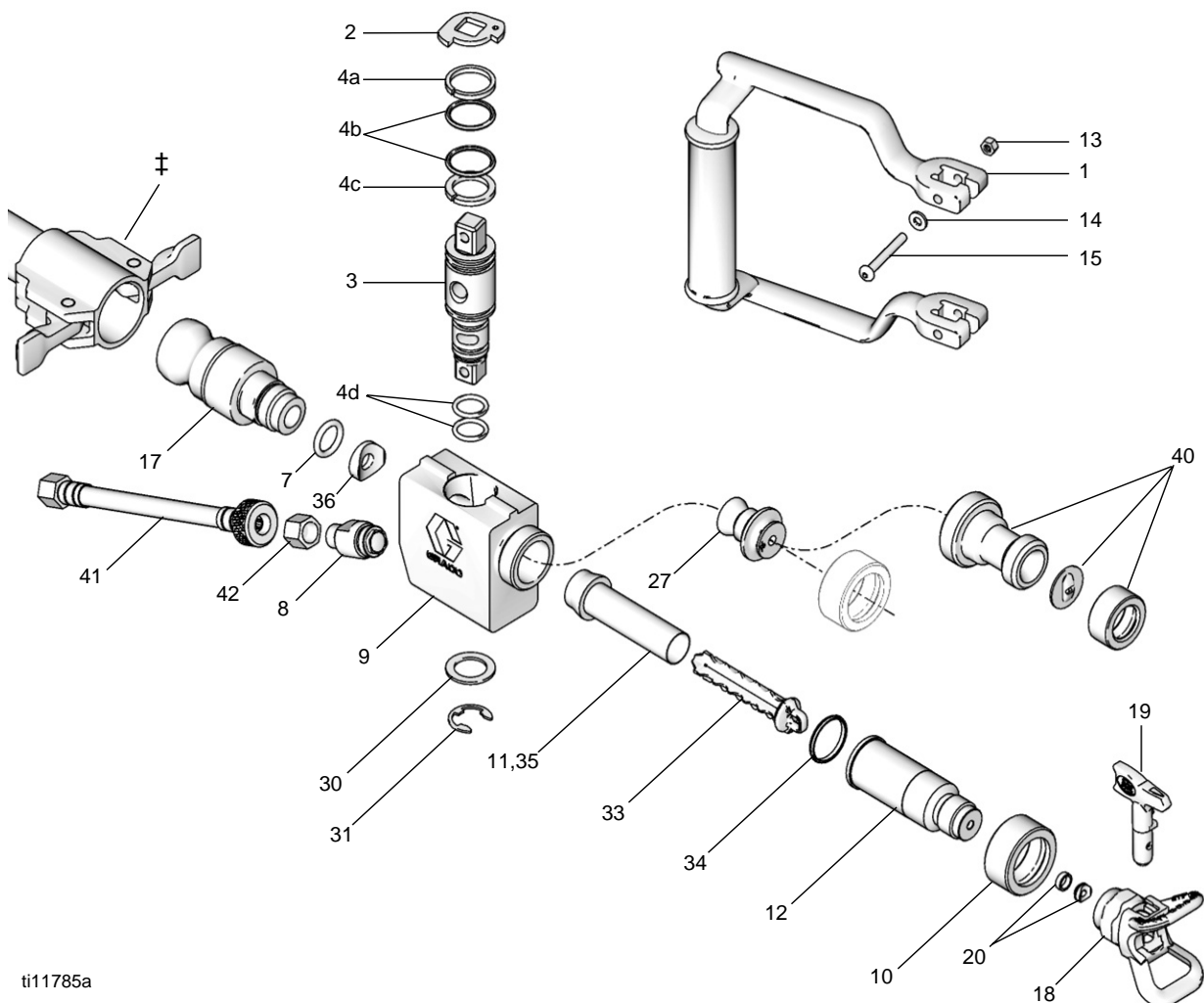

ti11785a

Ref	Part	Description	Qty	Ref	Part	Description	Qty
1	289921	HANDLE, valve, includes 2, 13, 14, 15	1	18	246215	GUARD, RAC X	1
2*	15T848	PLATE, stop, valve	1	19	HDA651	TIP, spray, RAC X (651)	1
3*	289916	SPOOL, valve	1	20	246453	KIT, gasket and seat (5 sets)	1
4*	289918	KIT, o-ring and bearing	1	27	248524	NOZZLE, 4 mm, rnd	1
4a		BEARING, upper	1	30*†	121548	WASHER, plain	1
4b		O-RING, fluid	2	31*†	121549	RING, retaining, E-ring	1
4c		BEARING, lower	1	33	277789	SUPPORT, filter	2
4d		O-RING, air	2	34	15U687	SEAL, adapter, filter, texture	1
7	111027	O-RING	1	35	289923	FILTER, screen, texture, 30 mesh, includes 33	1
8	289919	KIT, check valve	1	36*	289917	SEAT, spool, valve, includes 7	1
9	15T827	HOUSING, valve	1	40	287227	KIT, Accessory, Tex, Fine Finish	1
10	15T326	RING, retaining, nozzle	1	41	15U027	HOSE, air, extension	1
11	289922	FILTER, screen, texture, 18 mesh, includes 33	1	42	15U368	NUT, cap	1
12	15D727	ADAPTER, GHD RAC	1				
13	107110	LOCKNUT	2				
14	108193	WASHER, plain	2				
15	514237	SCREW, cap sch 10-32 x 1 1/2	2				
17	289920	SWIVEL, assy, texture heavy	1				

* Included in Spool Repair Kit 289916

† Included in O-ring and Bearing Kit 289918

‡ This applicator requires Graco coupler 289874

Spool Valve Repair



WARNING

Before performing any maintenance on applicator, read all warnings on front cover of this manual and **relieve pressure**.

Spool Valve Removal



Spool (3) and/or seat (36) may be rotated 180° for extended life if they are not worn through completely.

1. Remove swivel (17), o-ring (7) and seat (36).
2. Remove nut (13), screw (15), washer (14) and handle (1). Remove plate (2), clip (31) and washer (30).
3. Remove spool (3) from housing (9).

Spool Valve Installation

1. Apply grease (supplied with Kits 289916 and 289918) to spool, o-rings and bearings and inside of housing.
2. Assemble o-rings and bearings onto spool. Align bearing (4a, 4c) gaps away from ports in housing.
3. Install spool in housing. Secure with washer (30), and clip (31).
4. Install plate (2) onto spool (note location of orientation hole). Install handle with screw, washer and nut.
5. Apply grease to o-ring (7). Install seat (36), o-ring (7) and swivel (17).

Technical Data

Maximum fluid working pressure	1000 psi (6.9 MPa, 69 bar)
Maximum air working pressure	250 psi (1.7 MPa, 17 bar)
Air Requirements	30 scfm (0.84 m ³ /min) Maximum
Fluid Inlet Size	1 in.(m) cam and groove (Graco HP)
Air Inlet Size	1/4 npsm(m)
Wetted Parts	Aluminum, stainless steel, PE, POM, polyurethane, nitrile, nylon, PVC, tungsten carbide
Weight †	2.9 lb (1,3 kg)
Height	5.8 in. (14,7 cm)
Width	7.0 in. (17,8 cm)
Length †	12.7 in. (32,3 cm)

Sound Data without Air (applicator only):

Sound Pressure Level	84dB(A)*
Sound Power Level	83dB(A)*

Sound Data with Air (applicator only):

Sound Pressure Level	118dB(A)*
Sound Power Level	118dB(A)*

* Spraying simulated acoustical texture under typical conditions as specified by the material manufacturer.

† Airless configuration

For complete warranty information contact your local Graco distributor, call Graco customer service: 1-800-690-2894 or visit our website: www.graco.com.

All written and visual data contained in this document reflects the latest product information available at the time of publication. Graco reserves the right to make changes at any time without notice.

Original instructions. This manual contains English. MM 312879

Graco Headquarters: Minneapolis

International Offices: Belgium, China, Japan, Korea

GRACO INC. P.O. BOX 1441 MINNEAPOLIS, MN 55440-1441

Copyright 2008, Graco Inc. is registered to ISO 9001

www.graco.com
Revised 9/2010