

SATINATRICE CON ASPIRAZIONE
GLAZING MACHINES WITH DUST EXTRACTION

SR200AE

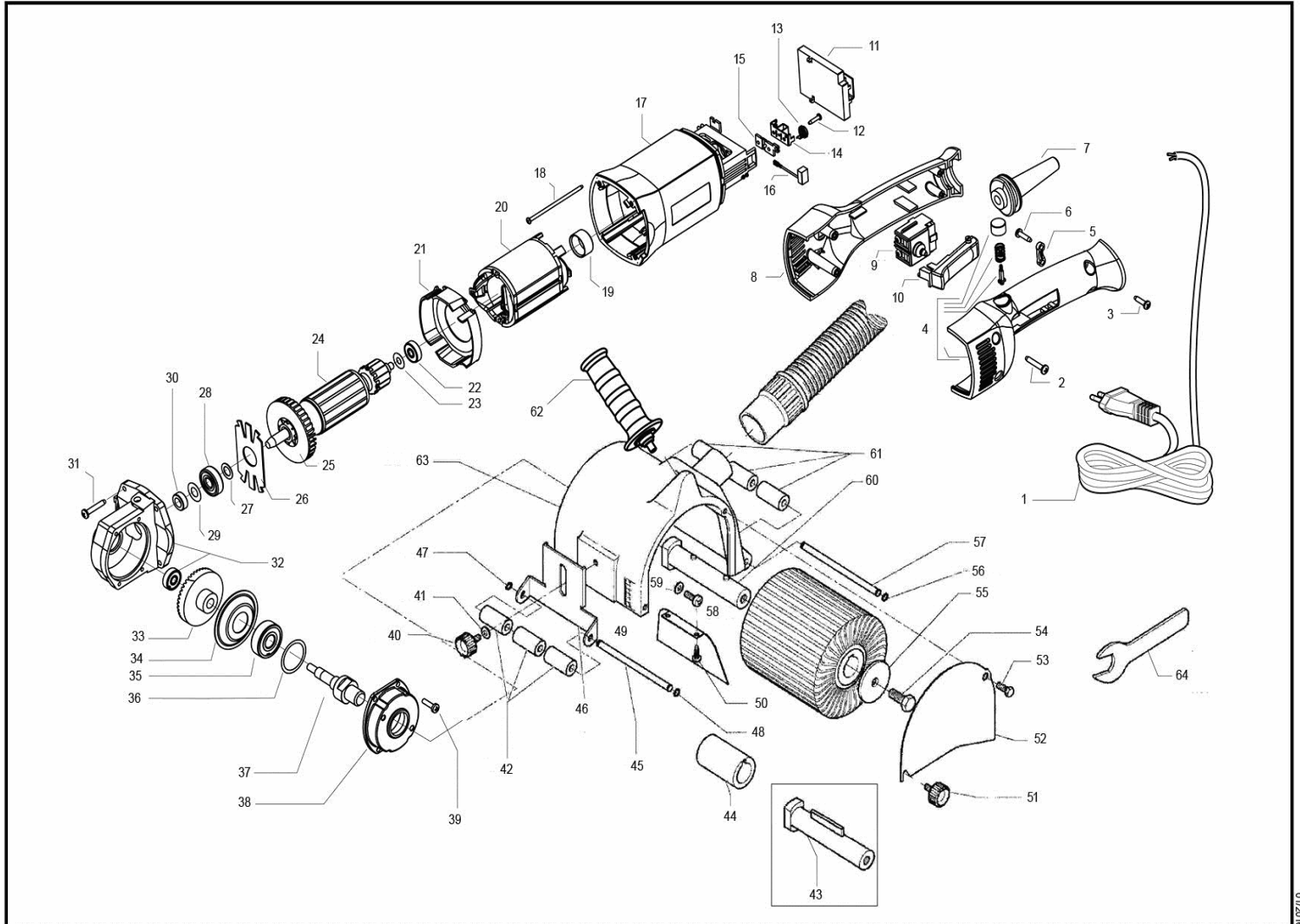

ID	ITEM	DESCRIPTION
001	9C2X1,0N484FOR	CABLE 2X1 (plug schuko Ø 4,8) mt.4 with fork
001	9C2X1,0NAU4	CABLE 2X1 (plug Australia) H07RN-F mt.4
001	9C2X1,0NGB4FOR	CABLE 2X1 (plug UK) with fork H07RN-F CENTRAL METAL PLUG
001	9C2X1,0R404FOR	CABLE 2X1 (plug D4) H07RN-F mt.4 with fork (only Swiss)
001	9C2X1,5V003FOR	CABLE 2X1,5 (without plug) mt.3,50 with fork
002	9.679	SCREW 4,2x25 (8x1") T.C.C.
003	9.660	SCREW 3,9x16 (7x5/8") T.C.C.
004	44.284/C	COMPLETE LOWER HANDLE+SWITCH BUTTON
005	444.14	CABLE CLAMP NYLON
006	9.660	SCREW 3,9x16 (7x5/8") T.C.C.
007	42.290	CABLE SLEEVE SS31TE
008	441.284	UPPER HANDEL
009	45.284	SWITCH 8(8) max 250V
010	38.286	SWITCH BUTTON (clamp open/close)
011	400.287	ELECTRONIC MODULE
011	400.146/110	ELECTRONIC MODULE 50HZ
012	9.551	SCREW 2,9x13 (4x1/2") T.C.C.
013	461.105	SPRING BRUSH HOLDER BURNISHED
014	46.105	BRUSH HOLDER
015	462.105	BRUSH HOLDER PLATE
016	47.105/10	BRUSH
017	31.284	MOTOR BODY
018	9.787	SCREW 2,9x70 T.C.C.
019	268.105	BEARING CAP
020	2.286/230	STATOR (V.230)
020	2.286/110	STATOR (V.110)
021	73.284	AIR BULKHEAD
022	9.14/10	BEARING 626ZZ1MC3E J NS7SQ
023	9.313	STEEL WASHER d23,9 x 20 s 0,3
024	1.287/230	ROTOR (V.230)
024	1.287/110	ROTOR (V.110)
025	15.105	FAN 36 BLADES
026	351.105	MOTOR BODY LITTLE COVER
027	9.298	STEEL WASHER d15 x 9,1 s 0,5
028	9.187/10	BEARING 629 2BRS R66 FA227
029	9.299	STEEL WASHER d18 x 9,1 s 0,15
030	54.119	RING LOCKING BEARING
031	9.679	SCREW 4,2x25 (8x1") T.C.C.
032	32.252/C	COMPLETE GEAR BOX
033	52.124	GEAR
034	35.105	FLANGE PLATE BA21-SL41
035	9.99/10	BEARING NSK 6201 DDUUCM D EA3S6
036	9.314	STEEL WASHER d31,9 x 26 s 0,1
037	51.105	SPINDLE SHAFT
038	33.105	FLANGE
039	9.637	SCREW M4 x 16 T.C.C. 8G BURNISHED
040	9.1407	KNOB M8x16
041	9.205	WASHER d 8 x 20 sp 2
042	826.204	SLIDING ROLL
043	512.204	SPINDLE WITH TAP
044	54.204	SPACER FOR BRUSH mm50 SR100AE
045	827.204	SHAFT FOR CONTROL ROLL
046	821.204	PROTECTION ROLL SUPPORT
047	9.119	SEEGER RING
048	9.119	SEEGER RING
049	822.204	PROTECTION VACUUM LOCK

ID	ITEM	DESCRIPTION
050	9.677	SCREW 3,9x 6,5 AUTOFIL.T.C.C.
051	9.1401	KNOB M5x10
052	823.204	COMPLETE LOCK
053	824.204	PROTECTION PIN
054	9.681	SCREW M8 x 20 T.E. UNI 5739
055	541.204	LOCK BRUSH SPACER
056	9.119	SEEGER RING
057	825.204	SHAFT FOR SLIDING ROLL
058	9.616	SCREW M5 x 14 TC + C/D STEEL 8.8 T.P.
059	9.331	TOOTHED WASHER
060	511.204	SPINDLE FOR GLAZING MACHINE
061	826.204	SLIDING ROLL
062	811.13	HANDLE
063	82.204/C	PROTECTION
064	83.030	SPANNER mm11 + mm13
064	83.13	SPANNER mm 17
064	831.030	SPANNER mm19